

9

WIRING SPECIFICATIONS

9-1. INDOOR UNIT POWER SUPPLIED FROM OUTDOOR UNIT (A-control application)

The following connection patterns are available.
The outdoor unit power supply patterns vary on models.

1:1 System

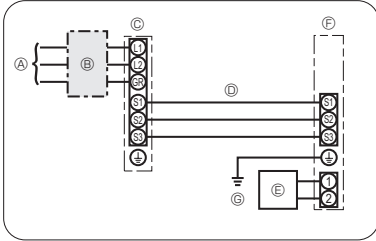

Simultaneous twin system

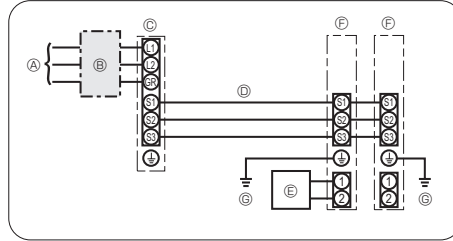

- Ⓐ Outdoor unit power supply
- Ⓑ Wiring circuit breaker or isolating switch
- Ⓒ Outdoor unit
- Ⓓ Indoor unit/outdoor unit connecting cords
- Ⓔ Remote controller
- Ⓕ Indoor unit
- Ⓖ Indoor unit earth

* Affix a label A that is included with the manuals near each wiring diagram for the indoor and outdoor units.

Indoor unit model	PLA-A12, 18, 24, 30 PCA, PKA	PLA-A36, 42
Indoor unit power supply	-	-
Minimum circuit ampacity	1A	2A
Maximum rating of overcurrent protective device	15A	15A

Outdoor unit model	A12	A18	A24	A30	A36	A42
Outdoor unit power supply	Single, 208/230 V, 60 Hz	Single, 208/230 V, 60 Hz	Single, 208/230 V, 60 Hz	Single, 208/230 V, 60 Hz	Single, 208/230 V, 60 Hz	Single, 208/230 V, 60 Hz
Breaker size	15A	15A	25A	30A	30A	30A
Minimum circuit ampacity	13A	13A	18A	25A	25A	26A
Maximum rating of overcurrent protective device	15A	20A	30A	40A	40A	40A
Wiring Wire No. x size	Outdoor unit power supply	2 × Min. AWG 14	2 × Min. AWG 14	2 × Min. AWG 12	2 × Min. AWG 10	2 × Min. AWG 10
	Outdoor unit power supply earth	1 × Min. AWG 14	1 × Min. AWG 14	1 × Min. AWG 12	1 × Min. AWG 10	1 × Min. AWG 10
	Indoor unit-Outdoor unit	*1 3 × AWG 16 (polar)	3 × AWG 16 (polar)	3 × AWG 16 (polar)	3 × AWG 16 (polar)	3 × AWG 16 (polar)
	Indoor unit earth	*1 1 × Min. AWG 16	1 × Min. AWG 16	1 × Min. AWG 16	1 × Min. AWG 16	1 × Min. AWG 16
Circuit rating	Remote controller-Indoor unit	*2 2 × AWG 22 (Non-polar)	2 × AWG 22 (Non-polar)	2 × AWG 22 (Non-polar)	2 × AWG 22 (Non-polar)	2 × AWG 22 (Non-polar)
	Outdoor unit L1-L2	*3 AC 208/230 V	AC 208/230 V	AC 208/230 V	AC 208/230 V	AC 208/230 V
	Indoor unit-Outdoor unit S1-S2	*3 AC 208/230 V	AC 208/230 V	AC 208/230 V	AC 208/230 V	AC 208/230 V
	Indoor unit-Outdoor unit S2-S3	*3 DC 24 V	DC 24 V	DC 24 V	DC 24 V	DC 24 V
Remote controller-Indoor unit	*3 DC 12 V	DC 12 V	DC 12 V	DC 12 V	DC 12 V	DC 12 V

*1. Max. 50 m, 165 ft

*2. The 10 m, 30 ft wire is attached in the remote controller accessory. Max 1500 ft

*3. The figures are NOT always against the ground.

S3 terminal has DC 24 V against S2 terminal. However between S3 and S1, these terminals are NOT electrically insulated by the transformer or other device.

- Notes:
1. Wiring size must comply with the applicable local and national code.
 2. Use copper supply wires.
 3. Use wires rated 300V or more for the power supply cables and the indoor/outdoor unit connecting cables.
 4. Install an earth longer than other cables.

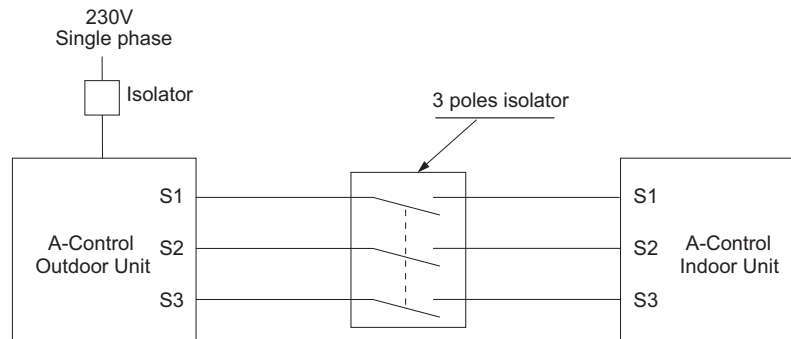

⚠ Warning:

In case of A-control wiring, there is high voltage potential on the S3 terminal caused by electrical circuit design that has no electrical insulation between power line and communication signal line. Therefore, please turn off the main power supply when servicing. And do not touch the S1, S2, S3 terminals when the power is energized. If isolator should be used between indoor unit and outdoor unit, please use 3-pole type.

9-2. M-NET WIRING METHOD

(Points to notice)

- (1) Outside the unit, transmission wires should stay away from electric wires in order to prevent electromagnetic noise from making an influence on the signal communication. Place them at intervals of more than 5cm. Do not put them in the same conduit tube.
- (2) Terminal block (TB7) for transmission wires should never be connected to 208/230V power supply. If it is connected, electronic parts on M-NET P.C. board may be burnt out.
- (3) Use 2-core x 1.25mm² [AWG16] shield wire (CVVS, CPEVS) for the transmission wire. Transmission signals may not be sent or received normally if different types of transmission wires are put together in the same multi-conductor cable. Never do this because this may cause a malfunction.

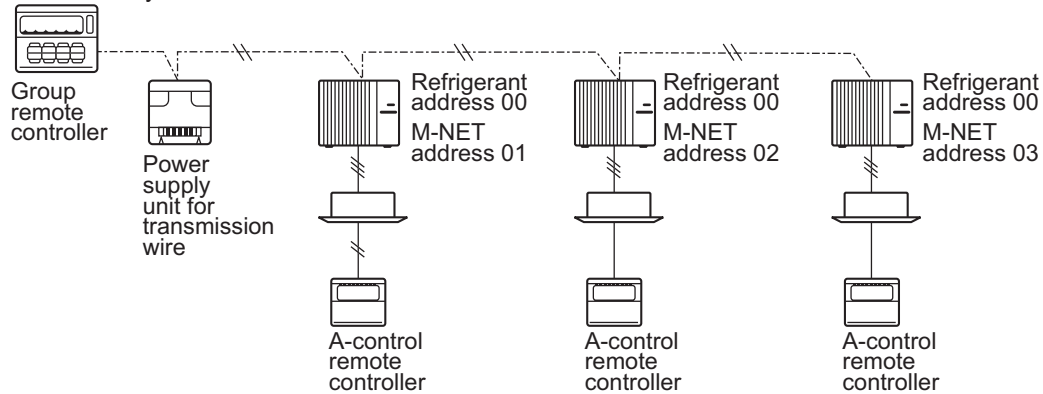

It would be ok if M-NET wire (non-polar, 2-cores) is arranged in addition to the wiring for A-control.

- (4) Ground only one of any appliances through M-NET transmission wire (shield wire). Communication error may occur due to the influence of electromagnetic noise.

“Ed” error will appear on the LED display of outdoor unit.
 “0403” error will appear on the central-control remote controller.

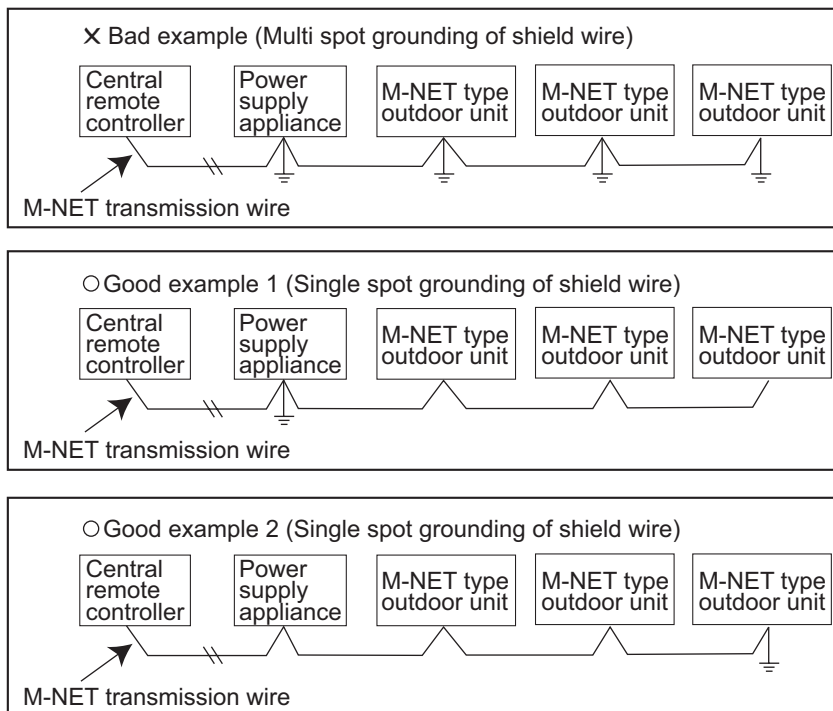

If there are more than two grounding spots on the shield wire, noise may enter into the shield wire because the ground wire and shield wire form one circuit and the electric potential difference occurs due to the impedance difference among grounding spots. In case of single spot grounding, noise does not enter into the shield wire because the ground wire and shield wire do not form one circuit.

To avoid communication errors caused by noise, make sure to observe the single spot grounding method described in the installation manual.

● M-NET wiring

- Use 2-core x 1.25mm² [AWG16] shield wire for electric wires. (Excluding the case connecting to system controller.)
- Connect the wire to the M-NET terminal block. Connect one core of the transmission wire (non-polar) to A terminal and the other to B. Peel the shield wire, twist the shield part to a string and connect it to S terminal.
- In the system which several outdoor units are being connected, the terminal (A, B, S) on M-NET terminal block should be individually wired to the other outdoor unit's terminal, i.e. A to A, B to B and S to S. In this case, choose one of those outdoor units and drive a screw to fix an ground wire on the plate as shown on the right figure.

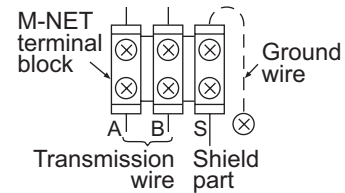

9-3-1. M-NET address setting

In A-control models, M-NET address and refrigerant address should be set only for the outdoor unit. Similar to CITY MULTI series, there is no need to set the address of outdoor unit and remote controller. To construct a central control system, the setting of M-NET address should be conducted only upon the outdoor unit. The setting range should be 1 to 50 (the same as that of the indoor unit in CITY MULTI system), and the address number should be consecutively set in a same group.

Address number can be set by using rotary switches (SW11 for ones digit and SW12 for tens digit), which is located on the M-NET board of outdoor unit. (Initial setting: all addresses are set to "0".)

<Setting example>

M-NET Address No.		1	2	...	50
Switching setting	SW11 ones digit			~	
	SW12 tens digit			~	

9-3-2. Refrigerant address setting

In case of multiple grouping system (multiple refrigerant circuits in one group), indoor units should be connected by remote controller wiring (TB5) and the refrigerant address needs to be set. Leave the refrigerant addresses to "00" if the group setting is not conducted. Set the refrigerant address by using DIP SW1-3 to -6 on the outdoor controller board. [Initial setting: all switches are OFF. (All refrigerant addresses are "00".)]

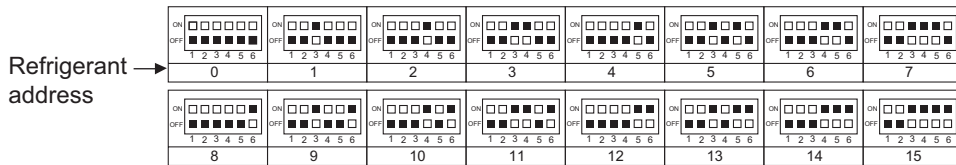

9-3-3. Regulations in address settings

In case of multiple grouping system, M-NET and refrigerant address settings should be done as explained in the above section. Set the lowest number in the group for the outdoor unit whose refrigerant address is "00" as its M-NET address.

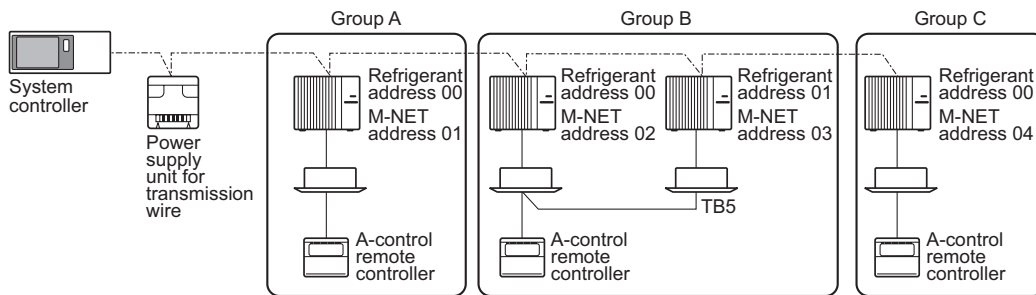

* Refrigerant addresses can be overlapped if they are in the different group.

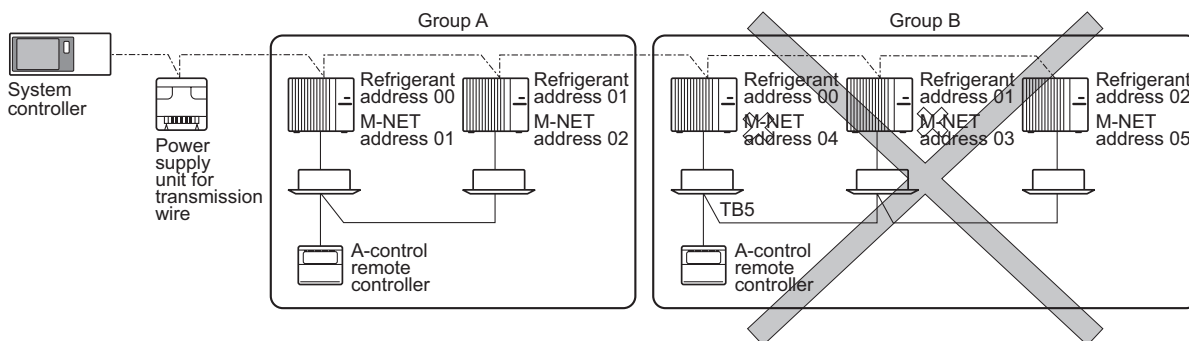

* In group B, M-NET address of the outdoor unit whose refrigerant address is "00" is not set to the minimum in the group. As "03" is right for this situation, the setting is wrong. Taking group A as a good sample, set the minimum M-NET address in the group for the outdoor unit whose refrigerant address is "00".